

PORTABLE

SCREW COMPRESSOR

CF1300M-31

SERIES

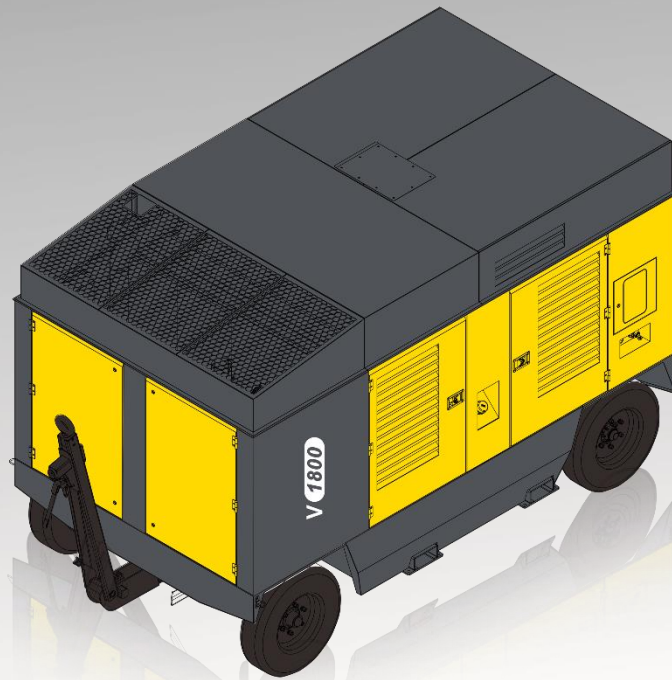

AIR PRESSURE: 31 bar

FAD: 1300 CFM/ 36.6 m³/min

Main Improvements:

Availability for wide application

CFAIR model is line up to suit a wide range of applications such as pneumatic tools drilling and blasting.

Easy Starting in Cold Weather

This compressor is superior in cold weather starting.

Meters with Luminous Lights

Meters on operation panel are equipped with luminous light.

Reliable Warning Signal

Warning signals have luminiscent diode and so become more reliable.

Double Element Air Cleaner

Double element air cleaner prevents dust from entering when replacing element.

Easy Cleaning of Cooling System

This compressor is so designed that the interiors of radiator and oil cooler and also fuel tank can be easily and quickly clean

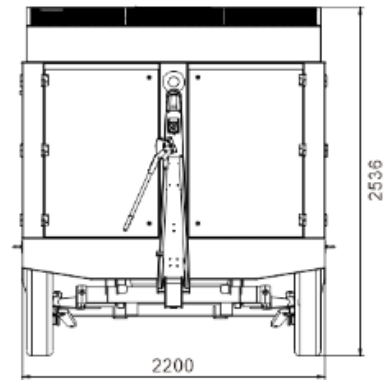
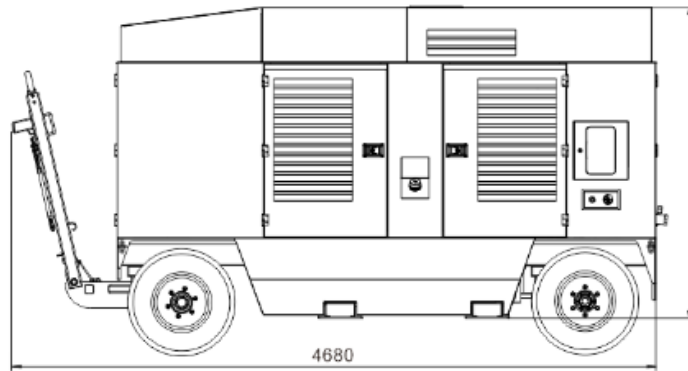

COMPRESSOR

Type	Rotary twin screw, single stage, oil-cooled
Free air delivery	36.6 m ³ /min(1300 cfm)
Working pressure	31 bar (449.5 psi)
Unloader	Suction port closing in connection with stepless speed regulator
Lubrication system	Forced lubrication by compression pressure
Driving system	Direct coupling with rubber
Oil cooling	Air-cooled
Air cleaner	Dry paper filter type

DETAILS

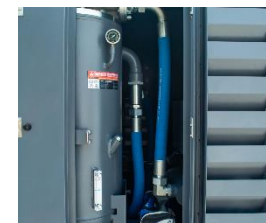

DIESEL ENGINE

Model	CUMMINS QSM15
Type	Water-cooled, 4-cycle, Turbo-Charged type
No. Of cylinders	6
Bore x stroke	135 mm x 169 mm
Total displacement	15 liters
Compression ratio	23 : 1
Rated output	563 kW(755hp) 1,900rpm
Max.torque	3000 N.m/approx.1,500rpm
Governor	Electric
Fuel System	Diesel
Starting motor	DC 24 V
Battery	150AH X 2 pcs, 950CCA
Air cleaner	Two-stage dry type

INSTRUMENTS & GAUGES

EMERGENCY STOP DEVICES

- Oil pressure switch
- Engine coolant temperature switch
- Discharge air temperature switch
- Compressor oil temperature switch
- Engine speed down switch

GAUGES

Air Pressure gauge	Tachometer
Fuel level gauge	Engine oil pressure
Stop button	Engine coolant temp
Starter switch	Discharge air temp
Starting Loader	Discharge air pressure
	Hourmeter

LIQUID CAPACITY

Fuel tank capacity	800 liters
Engine oil capacity	50 liters
Coolant capacity	160 liters
Compressor oil capacity	105 liters

DIMENSIONS & WEIGHT

L x W x H	4680 x 2200 x 2536 mm
Weight	8200 Kg
20ft container	1 sets
40HQ container	2 sets



HANGZHOU CAIFULL PRECISION MACHINERY CO.,LTD

No.7 Liuxia Village Industrial Block, Xihu District, Hangzhou City, Zhejiang Province, China.

TEL: 0086-571-85128760 FAX: 0086-571-85128761

E-mail:owen@caifuair.com

http: www.caifuair.com



SAFETY

- Operate safely in accordance with proper operation manual.
- To prevent trouble and accidents, perform daily and preventive maintenance checks without fail.

